

V300 SERIES PROJECT-OUT

FEATURES

- ◇ **Commercial Framing System**
 - 3 1/4" main frame
- ◇ **Enhanced Design**
 - Mitered and welded corners
- ◇ **Glazing**
 - 1" insulated glass
- ◇ **Integral Nailing Fin**
- ◇ **Hardware**
 - Multi-point locking system with fold-down handle to avoid interference with window blinds
 - Heavy commercial 4-bar arms
 - Low profile flat lock
- ◇ **Screen**
 - Flex Screen
- ◇ **Colors**
 - White or Sandstone vinyl (interior/exterior)

BENEFITS

- ◇ The capacity to match exterior colors for unique project facades
- ◇ The ability to facilitate large sizes for taller and wider window openings

PERFORMANCE

- ◇ **Structural & Thermal** (test reports or thermal simulations available upon request)

| Model | Project-Out |
|---|-------------|
| NAFS Rating | CW-50 |
| Structural Load P.S.F. | 75.19 |
| Air at 50 MPH (cfm/ft ²) | <0.30 |
| Water (No Penetration) P.S.F. | 7.5 |
| U-Value (ranges based on multiple Low-E/Argon combinations) | 0.18-0.28 |
| SHGC (ranges based on multiple Low-E/Argon combinations) | 0.10-0.42 |

Window test size: 60" × 32"

OPTIONS

- ◇ **Available Configurations**
 - Project-out
- ◇ **Muntin Choices**
 - Internal or simulated divided lites available
- ◇ **Limited Travel Hardware**
- ◇ **Screen**
 - Extruded aluminum screen frame with BetterVue™ mesh with WaterShed® technology
 - Extruded aluminum screen frame with aluminum wire mesh
 - Extruded aluminum screen frame with sunscreen mesh
 - Extruded aluminum screen frame with stainless steel 0.009" thickness mesh
- ◇ **Glazing**
 - Multiple Low-E and argon glazing choices
 - Triple glazing (Energy TG)
 - Capillary tubes
 - Wide variety of glazing, tinting and thickness options
- ◇ **Panning & Trim Choices**
 - Wide variety of panning, receptor and trim available
- ◇ **Mulling**
 - Wide variety of structural mulls
- ◇ **Colors**
 - High-performance Textured Black laminate (interior/exterior)
 - High-performance Textured Black laminate (exterior only with White vinyl or Textured Black laminate interior)
 - High-performance Textured Dark Bronze laminate (exterior only with White vinyl interior)
 - Twelve painted exterior colors (with White or Sandstone vinyl interior)
 - Unlimited custom painted exterior colors

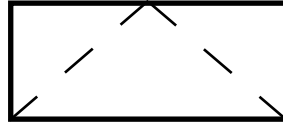

V300 PROJECT-OUT

This document contains confidential and proprietary information intended for the private use of Quaker.
© 2016 Quaker Window Products Co., INC. All rights reserved.
Quaker reserves the right to change any/all designs without notice. Due to periodic re-certification requirements, result shown may vary.

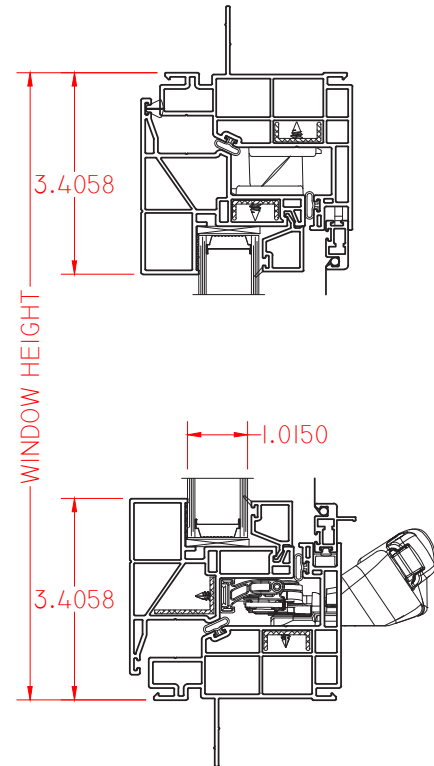
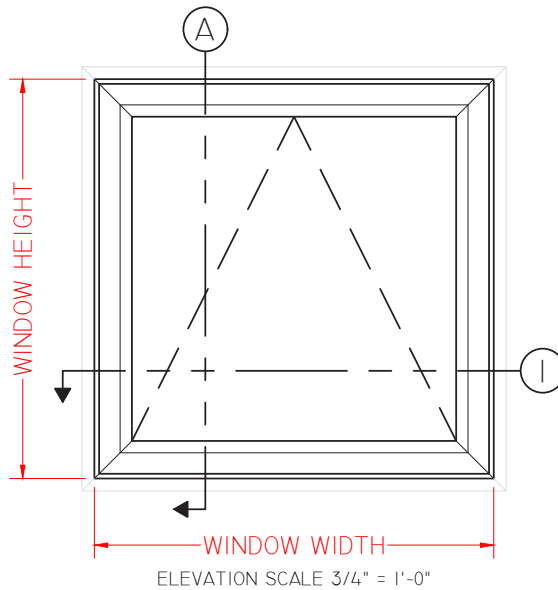
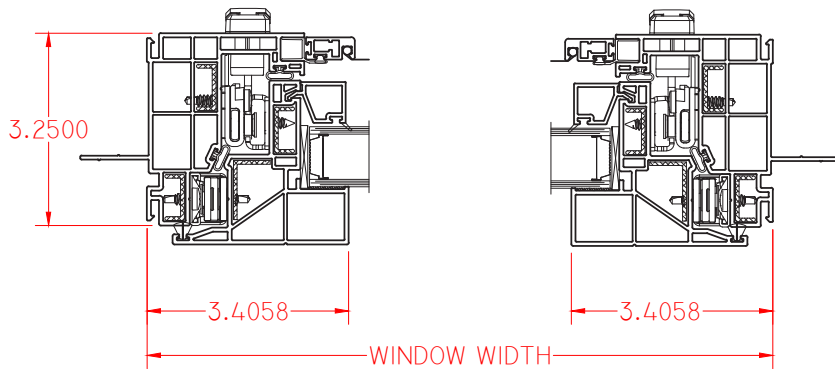

SCALE 1:3

Our products are tested to the standards of and certified by some of the foremost organizations in the fenestration industry.

